

PVC PIPE BOW PLANS

Parts List		
ITEM NO.	NO. REQ'D	DESCRIPTION
1	1	1/2" PVC PRESSURE PIPE - 48" LONG
2	1	1" PIPE FOAM INSULATION - 5" LONG
3	1	#48 BRAIDED NYLON STRING - 54" LONG
4	2	1/4" COAXIAL CABLE CLIP
5	1	ELECTRICAL TAPE FOR HANDLE
6	2	PLASTIC ZIP TIES
7	1	GLUE
8	1	4" HEAT SHRINK WRAP TUBING FOR SERVING

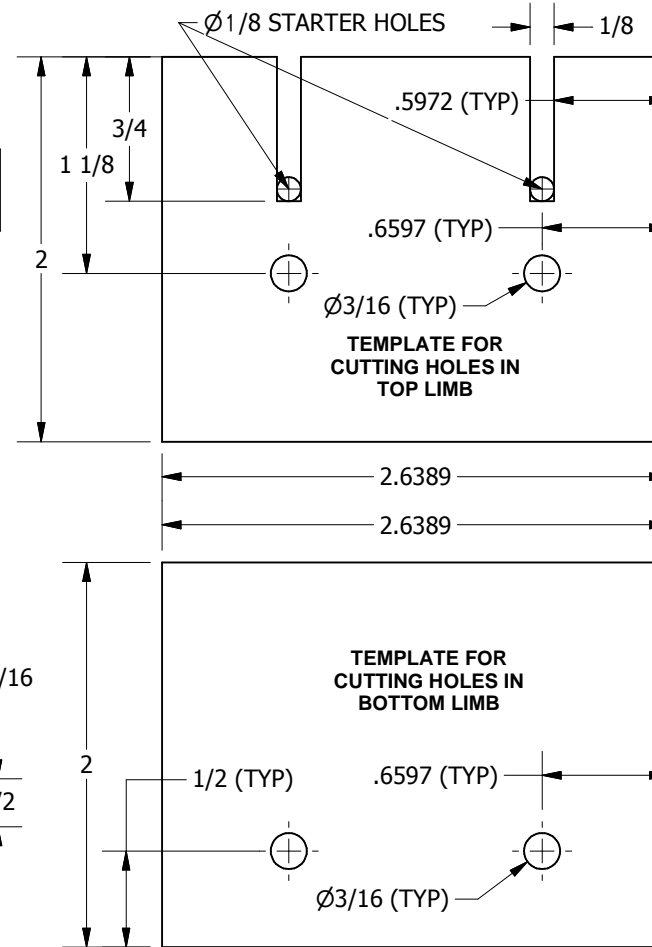
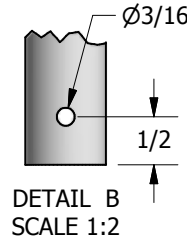
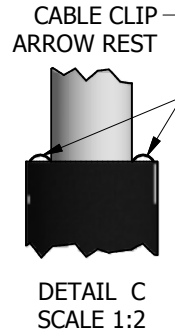
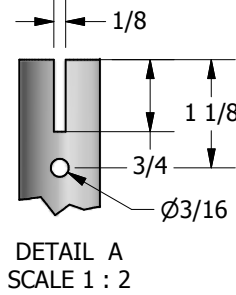

BUILDING INSTRUCTIONS

- CUT THE PVC PIPE TO LENGTH. SAND EDGES SMOOTH AND REMOVE ANY WRITING ON PIPE. I USE ACETONE OR 200 GRIT SANDPAPER TO DO THIS.
- DRILL 3/16" HOLES IN THE END OF THE PIPE YOU DEEM THE LOWER LIMB. IT IS VERY IMPORTANT THAT THE HOLES GO THROUGH THE CENTER OF THE PIPE AND THAT THE HOLES LINE UP. USE A DRILL PRESS IF YOU HAVE ONE OR WRAP THE TEMPLATE PROVIDED AROUND THE LIMB. OTHERWISE, JUST BE CAREFUL.
- DRILL 3/16" HOLES IN THE UPPER LIMB. AGAIN, MAKE SURE THOSE HOLES LINE UP FROM FRONT TO BACK. YOU ALSO NEED TO MAKE SURE THE TOP AND BOTTOM HOLES LINE UP.
- CUT THE SLOT IN THE UPPER LIMB. I DRILL A 1/8" STARTER HOLE FIRST WHERE THE BOTTOM OF THE SLOT WILL BE AND USE A HACKSAW TO CUT FROM THE TOP OF THE PIPE TO THE HOLE. TRIM THE SLOT UP WITH A UTILITY KNIFE.

(STEP 5 IS OPTIONAL. DO IT IF YOU WANT TO MAKE A STIFFER BOW. OTHERWISE SKIP TO STEP #6)
- SQUIRT EXPANDING FOAM INSIDE THE ENTIRE LENGTH OF THE BOW.
- IF YOU ARE GOING TO PAINT THE BOW (I USE SPRAY PAINT), CLEAN THE PIPE WITH LACQUER THINNER BEFORE YOU PAINT IT.
- MARK THE BOW WHERE THE TOP AND BOTTOM OF THE FOAM HANDLE WILL BE. COVER THIS AREA WITH GLUE AND THEN PUT THE FOAM HANDLE IN PLACE.
- SLIDE THE CABLE CLIPS (ARROW RESTS) OVER THE TOP OF THE FOAM HANDLE ON THE LEFT AND RIGHT SIDES OF THE BOW. ONE SIDE OF THE CLIP SHOULD BE BETWEEN THE PIPE AND THE FOAM HANDLE AND THE OTHER SIDE SHOULD BE ON THE OUTSIDE OF THE HANDLE. SECURE THE CLIPS IN PLACE WITH A ZIP TIE. PLACE ANOTHER ZIP TIE AROUND THE BOTTOM OF THE FOAM HANDLE TO HELP SECURE THE HANDLE IN PLACE. CUT OFF THE ZIP TIE EXCESS AS CLOSE AS YOU CAN.
- WRAP THE ENTIRE HANDLE WITH ELECTRICAL TAPE.

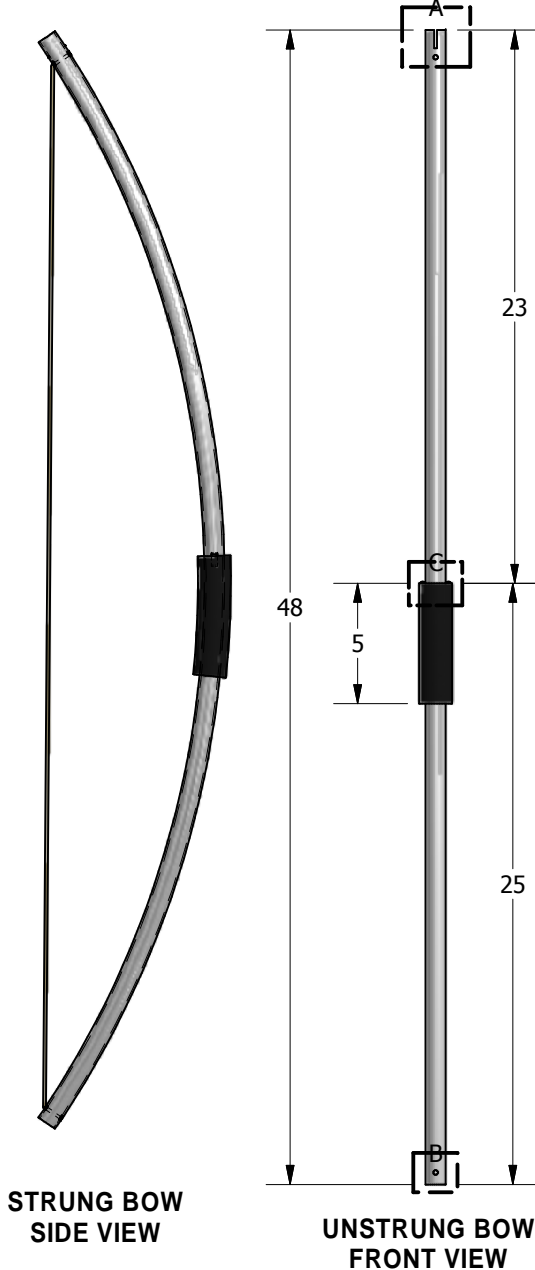

STRINGING INSTRUCTIONS

- TIE A KNOT IN ONE END OF THE STRING AND THEN RUN THE OTHER END THROUGH BOTH HOLES (FRONT TO BACK) IN THE BOTTOM LIMB.
- RUN THE SAME STRING END THROUGH BOTH HOLES IN THE TOP LIMB, BACK TO FRONT.
- WHILE NOT BENDING THE BOW, PULL THE STRING TAUT AND TIE ANOTHER KNOT IN IT AS CLOSE TO THE BOW AS YOU CAN. NOW THE STRING WILL ALWAYS BE WITH THE BOW.
- TO STRING THE BOW, BEND THE BOW TO THE DESIRED BRACE HEIGHT AND PULL THE STRING TAUT THROUGH THE TOP HOLES. WRAP THE EXCESS STRING AROUND THE TOP LIMB AND THROUGH THE SLOT CUT IN THE TOP LIMB. THE KNOT YOU TIED EARLIER SHOULD HOLD THE STRING IN PLACE. YOU MAY HAVE TO ADJUST THE KNOT'S POSITION TO ACHIEVE THE DESIRED BRACE HEIGHT.